

# Panasonic®

## Advanced Hybrid System

## User Guide

### for Single Line Telephone





---

















Model No. **KX-TA824**

















Please read this guide before using and save for future reference.

# Features List



















 Feature number  
  Off-hook  
  On-hook  
  Talk

Desired Feature	Operation
<b>Making Calls</b>	
Calling	To an extension  ► <span style="border: 1px solid black; padding: 2px;">extension no.</span> ► 
	To an external party  ► <span style="border: 1px solid black; padding: 2px;">phone no.</span> ► 
Redial	 ► <span style="border: 1px solid black; padding: 2px;">8</span> <span style="border: 1px solid black; padding: 2px;">0</span> / <span style="border: 1px solid black; padding: 2px;">#</span> <span style="border: 1px solid black; padding: 2px;">#</span> ► 
Calling an operator	 ► <span style="border: 1px solid black; padding: 2px;">0</span> ► 
Speed Dialing (Personal)	To store  ► <span style="border: 1px solid black; padding: 2px;">2</span> <span style="border: 1px solid black; padding: 2px;">*</span> ► <span style="border: 1px solid black; padding: 2px;">personal speed dial no.</span> ► <span style="border: 1px solid black; padding: 2px;">desired no.</span> ► ► <span style="border: 1px solid black; padding: 2px;">#</span> ► 
	To dial  ► <span style="border: 1px solid black; padding: 2px;">1</span> <span style="border: 1px solid black; padding: 2px;">*</span> / <span style="border: 1px solid black; padding: 2px;">#</span> ► <span style="border: 1px solid black; padding: 2px;">personal speed dial no.</span> ► 
Speed Dialing (System)	To dial  ► <span style="border: 1px solid black; padding: 2px;">*</span> ► <span style="border: 1px solid black; padding: 2px;">system speed dial no.</span> ► 
<b>Receiving Calls</b>	
Picking up a call	 ► <div style="border: 1px dashed black; padding: 10px; display: inline-block; margin-left: 20px;"> <p style="margin: 0;">Directed</p> <p style="margin: 0;"><span style="border: 1px solid black; padding: 2px;">4</span> ► <span style="border: 1px solid black; padding: 2px;">extension no.</span></p> <p style="margin: 0;">Group</p> <p style="margin: 0;"><span style="border: 1px solid black; padding: 2px;">4</span> <span style="border: 1px solid black; padding: 2px;">0</span></p> </div> ► 











# Features List

Desired Feature	Operation	
<b>When the Dialed Extension is Busy/No Answer</b>		
Automatic Callback Busy	<b>To set</b> <i>While hearing a busy tone</i>  ▶ <b>6</b> ▶ 	<b>To call</b> <i>If you hear callback ringing</i> 
Message Waiting	Sender	<b>To leave a notification</b>  ▶ <b>7</b> <b>0</b> ▶ <b>1</b> ▶ <b>desired extension no.</b> ▶ ▶ <b>#</b> / <b>0</b> ▶  <hr/> <b>To cancel a notification</b>  ▶ <b>7</b> <b>0</b> ▶ <b>2</b> ▶ <b>desired extension no.</b> ▶ ▶ <b>#</b> / <b>0</b> ▶ 
	Receiver	<b>To clear all notifications</b>  ▶ <b>7</b> <b>0</b> <b>0</b> ▶ <b>#</b> ▶ 
Call Waiting	Sender	<i>While hearing a busy tone</i> <b>1</b> ▶ Wait for an answer. ▶ 
	Receiver	 ▶ <div style="border: 1px dashed black; padding: 10px; display: inline-block; margin: 10px;"> <p><b>For outside calls</b></p> <p><b>7 3 1 1 #</b> Set</p> <p><b>7 3 1 0 #</b> Cancel</p> <p><b>For intercom calls</b></p> <p><b>7 3 2 1 #</b> Set</p> <p><b>7 3 2 0 #</b> Cancel</p> </div> ▶  <hr/> <b>To talk to the new party</b> <i>While hearing the Call Waiting tone</i> <b>Terminating a current status</b>  ▶  ▶ 



# Features List

Desired Feature	Operation
<b>During a Conversation</b>	
Holding a call	<p><b>Holding</b></p>  ►  <p>To retrieve a call at the holding extension</p> 
	<p>To retrieve an outside call from another extension</p>  ► <b>5</b> <b>3</b> ► <b>held line no.</b> ► 
Transferring a call	 ► <b>extension no.</b> To an extension ► Wait for an answer. ►  ► <b>Announce.</b> ► 
<b>Useful Features</b>	
Paging	<p><b>To page</b></p>  ► <div style="border: 1px dashed black; padding: 5px; margin: 5px;"> <p>All extensions  <b>3</b> <b>3</b> <b>0</b></p> <p>Group  <b>3</b> <b>3</b> ► <b>group no.</b></p> <p>All external speakers  <b>3</b> <b>4</b></p> <p>All extensions &amp; external speakers  <b>3</b> <b>3</b> <b>*</b></p> </div> ►  <b>Announce.</b>
<p><b>To answer an announced page</b></p>  ► <div style="border: 1px dashed black; padding: 5px; margin: 5px;"> <p>From a telephone speaker  <b>4</b> <b>3</b></p> <p>From an external speaker  <b>4</b> <b>3</b></p> </div> ► 	
Three-party conference	 ► <b>third party's no.</b> ►  ►  <b>3</b>
Setting Absent Message	<p><b>To set</b></p>  ► <b>7</b> <b>5</b> ► <b>message no.</b> ► <b>parameter (if required)</b> ► <b>#</b> ► 
	<p><b>To cancel</b></p>  ► <b>7</b> <b>5</b> <b>0</b> <b>#</b> ► 

# Features List

Desired Feature	Operation																										
<b>Useful Features</b>																											
Log-In/Log-Out	 ► <table border="1" data-bbox="389 263 663 331" style="display: inline-table; vertical-align: middle;"> <tr> <td style="text-align: center;">7</td> <td style="text-align: center;">3</td> <td style="text-align: center;">6</td> <td style="text-align: center;">0</td> <td style="text-align: center;">#</td> </tr> <tr> <td style="text-align: center;">7</td> <td style="text-align: center;">3</td> <td style="text-align: center;">6</td> <td style="text-align: center;">1</td> <td style="text-align: center;">#</td> </tr> </table> <span style="display: inline-block; vertical-align: middle; margin-left: 10px;">For Log-In For Log-Out</span> ► 	7	3	6	0	#	7	3	6	1	#																
7	3	6	0	#																							
7	3	6	1	#																							
Forwarding a call	 ► <table border="1" data-bbox="364 598 487 638" style="display: inline-table; vertical-align: middle;"> <tr> <td style="text-align: center;">7</td> <td style="text-align: center;">1</td> </tr> </table> ► <div style="border: 1px dashed black; padding: 10px; display: inline-block; vertical-align: middle; margin-left: 20px;"> <p><b>All calls</b></p> <p><table border="1" data-bbox="532 391 800 430" style="display: inline-table; vertical-align: middle;"> <tr> <td style="text-align: center;">1</td> <td style="text-align: center;">extension no.</td> <td style="text-align: center;">#</td> </tr> </table></p> <p><b>Busy/No answer</b></p> <p><table border="1" data-bbox="532 446 800 486" style="display: inline-table; vertical-align: middle;"> <tr> <td style="text-align: center;">2</td> <td style="text-align: center;">extension no.</td> <td style="text-align: center;">#</td> </tr> </table></p> <p><b>To an outside line</b></p> <p><table border="1" data-bbox="532 502 912 550" style="display: inline-table; vertical-align: middle;"> <tr> <td style="text-align: center;">3</td> <td style="text-align: center;">line access code</td> <td style="text-align: center;">phone no.</td> <td style="text-align: center;">#</td> </tr> </table></p> <p><b>Follow Me</b></p> <p><table border="1" data-bbox="532 566 845 606" style="display: inline-table; vertical-align: middle;"> <tr> <td style="text-align: center;">5</td> <td style="text-align: center;">your extension no.</td> <td style="text-align: center;">#</td> </tr> </table></p> <p><b>Cancel Follow Me</b></p> <p><table border="1" data-bbox="532 622 845 662" style="display: inline-table; vertical-align: middle;"> <tr> <td style="text-align: center;">8</td> <td style="text-align: center;">your extension no.</td> <td style="text-align: center;">#</td> </tr> </table></p> <p><b>Cancel</b></p> <p><table border="1" data-bbox="532 678 644 718" style="display: inline-table; vertical-align: middle;"> <tr> <td style="text-align: center;">0</td> <td style="text-align: center;">#</td> </tr> </table></p> <p><b>To Voice Mail</b></p> <p><b>All calls</b></p> <p><table border="1" data-bbox="532 782 845 821" style="display: inline-table; vertical-align: middle;"> <tr> <td style="text-align: center;">1</td> <td style="text-align: center;">VPS extension no.</td> <td style="text-align: center;">#</td> </tr> </table></p> <p><b>Busy/No answer</b></p> <p><table border="1" data-bbox="532 837 845 877" style="display: inline-table; vertical-align: middle;"> <tr> <td style="text-align: center;">2</td> <td style="text-align: center;">VPS extension no.</td> <td style="text-align: center;">#</td> </tr> </table></p> </div> ► 	7	1	1	extension no.	#	2	extension no.	#	3	line access code	phone no.	#	5	your extension no.	#	8	your extension no.	#	0	#	1	VPS extension no.	#	2	VPS extension no.	#
7	1																										
1	extension no.	#																									
2	extension no.	#																									
3	line access code	phone no.	#																								
5	your extension no.	#																									
8	your extension no.	#																									
0	#																										
1	VPS extension no.	#																									
2	VPS extension no.	#																									
Do Not Disturb (DND)	 ► <table border="1" data-bbox="364 973 520 1013" style="display: inline-table; vertical-align: middle;"> <tr> <td style="text-align: center;">7</td> <td style="text-align: center;">1</td> </tr> </table> ► <table border="1" data-bbox="565 957 800 1029" style="display: inline-table; vertical-align: middle;"> <tr> <td style="text-align: center;">4</td> <td style="text-align: center;">#</td> <td style="text-align: center;">Set</td> </tr> <tr> <td style="text-align: center;">0</td> <td style="text-align: center;">#</td> <td style="text-align: center;">Cancel</td> </tr> </table> ► 	7	1	4	#	Set	0	#	Cancel																		
7	1																										
4	#	Set																									
0	#	Cancel																									
Locking your extension	 ► <p style="text-align: center; margin-left: 20px;">(Lock code is 4 digits.)</p> <table border="1" data-bbox="403 1125 901 1197" style="display: inline-table; vertical-align: middle;"> <tr> <td style="text-align: center;">7</td> <td style="text-align: center;">7</td> <td style="text-align: center;">lock code</td> <td style="text-align: center;">lock code</td> <td style="text-align: center;">#</td> <td style="text-align: center;">Lock</td> </tr> <tr> <td style="text-align: center;">7</td> <td style="text-align: center;">7</td> <td style="text-align: center;">lock code</td> <td style="text-align: center;">#</td> <td style="text-align: center;">Unlock</td> <td></td> </tr> </table> ► 	7	7	lock code	lock code	#	Lock	7	7	lock code	#	Unlock															
7	7	lock code	lock code	#	Lock																						
7	7	lock code	#	Unlock																							
Clearing the setting	 ► <table border="1" data-bbox="386 1252 543 1292" style="display: inline-table; vertical-align: middle;"> <tr> <td style="text-align: center;">7</td> <td style="text-align: center;">9</td> <td style="text-align: center;">#</td> </tr> </table> ► 	7	9	#																							
7	9	#																									

# Features List

Desired Feature	Operation		
<b>To Make Use of Voice Mail Service</b>			
Listening Message	From your Own Extension	 ► Extension No. of the VPS ► ► Password # • If you have no password, you can skip the last step.	■ <b>KX-TVA series</b> [1] Listen to Message [2] Deliver Message [3] Mailbox Management [4] Automated Attendant [5] Message Notification [6] Other Features [*] End Call  ■ <b>KX-TVS series</b> [1] Listen to Message [2] Deliver Message [3] Check Mailbox Distribution [4] Automated Attendant [5] Mailbox Management [6] Other Features [*] End Call
	From someone else's extension	 ► Extension No. of the VPS ► ► # 6 ► * ► ► Mailbox No. ► ► Password # • If you have no password, you can skip the last step.	
Leaving Message	 ► Extension No. of the VPS ► # 6 ► ► Mailbox No. / # 1 first 3 or 4 of name ► ► Leave Message		
During Playback	[0] Repeat Voice Guidance [*] Exit Menu		

***NOTE***

---

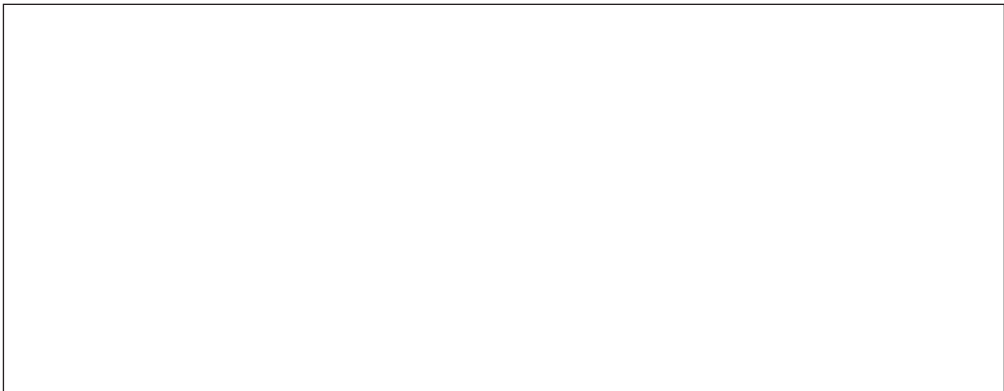

**Panasonic Consumer Electronics  
Company Division of Panasonic  
Corporation of North America**  
One Panasonic Way,  
Secaucus, New Jersey 07094  
<http://www.panasonic.com/csd>

**Panasonic Puerto Rico, Inc.**  
Ave. 65 de Infantería, Km. 9.5,  
San Gabriel Industrial Park, Carolina,  
Puerto Rico 00985

© 2005 Panasonic Communications Co., Ltd. All Rights Reserved.

**PSQX3430ZA** KK0405ST0